



# High precision absolute pressure transmitter

## JUN-E30

JUN-E30 pressure transmitter is the world's advanced pressure sensor technology Echnology and packaging process, carefully developed an ultra-high performance pressure transmitter, measuring precision. The highest degree is  $\pm 0.025\%$ , and the range ratio can reach 100:1. The transmitter has a built-in mono-crystalline silicon sensor, and the input from the DC 4 to 20mA signal corresponding to the measured pressure.

Products are suitable for the pressure measurement of gas, liquid, steam and other process fluids, which can be used in environments with explosion-proof requirements.

Through mutual communication with intelligent terminals, various functions can be set, adjusted and monitored for output signals.

### Standard layout

#### Export

Export Signal: DC 4 ~ 20mA

Output signal range: DC3.8~20.8mA (maximum)

#### Supply voltage

DC16.5~55V(See Figure 1 for details)

#### Load impedance

0~2199  $\Omega$  is the working status (see Figure 1 for details)

250~600  $\Omega$  HART

#### Communication mode

HART、PROFIBUS-PA、FOUNDATION Field-bus

#### Determine the pressure range

Scope code	Range	Measurement range
A40	40kPa	Minimum range 10kPa, 0~40kPa
A250	250kPa	Minimum range 12.5kPa, 0~250kPa
A1K	1MPa	Minimum range 50kPa, 0~1MPa
A10K	10MPa	Minimum range 500kPa, 0~10MPa

Note: The actual lower limit of range can not reach the absolute zero value, can only be approximated to 0kPa, calculated by the zero value.

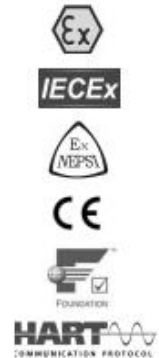

#### Overload capacity

25MPa

#### Use the temperature range

Ambient temperature range: -40 to 85°C

Integrated LCD display: -20~70°C

Temperature range: silicone oil-filled sensor-40-120°C filled with inert filling fluid-45-160°C

#### Use humidity range

5%~100%RH@40°C

#### Storage temperature range

-40~110°C, Integrated LCD display: -40~85°C

#### Levels of protection

IP67

#### Failure alarm signal

When the added pressure exceeds the upper limit of range, export alarm current value, lower limit to 3.8mA and upper limit to 20.8mA.

#### Precision

$\pm 0.025\%$ 、 $\pm 0.05\%$ 、 $\pm 0.075\%$ 、 $\pm 0.1\%$ (See Table 2 for details)

#### Temperature characteristic

Total impact volume in the range of -20 to 80°C:  $\pm (0.1 + 0.15 TD)\%$  range upper limit

### Time index

The total damping time constant is equal to the electronic circuit component and the sensing membrane box damping The sum of the time constants. Damping time of electronic circuit components: 0~100S range adjustable. Damping time of the sensing membrane cartridge: 0.2S.

### Long-term stability

±0.15%range Upper limit / 10 years

### Quick operation menu

Function	Explain
PV zero clearing	So that the current simulation export corresponds to the zero pressure value
Zero (point) adjustment	The actual export was set to 4mA using the reference pressure
Full point adjustment	The actual export was set to 20mA using the reference pressure
Factory data rese	During a debugging error, restore the factory backup data

### Material quality

Can provide a variety of anti-corrosion materials of the liquid connecting parts.

316L stainless steel, 316L stainless steel gold-plated, hab C, tantalum, Monnell, etc

Wiring box material: aluminum alloy exterior spraying epoxy resin

### Seal into the liquid

Silicone oil, inert filling fluid, etc

### Distribution interface

M20\*1.5、1/2NPT

### Weight

About 2kg (excluding mounting bracket, process connection accessories)

### Additional instructions

Grade 1, Zone 1 / 2, Group G, Ex d IIC T6

-30°C≤Tamb≤+75°C Process temperature =85°C

Grade 1, Zone 1 / 2, Group G, Ex d IIC T5

-30°C≤Tamb≤+80°C Process temperature =100°C

Grade 1, Zone 1 / 2, Group G, Ex d IIC T4

-30°C≤Tamb≤+80°C Process temperature =110°C

Grade 1, Zone 2, Group D, Ex tD A21 T85

-30°C≤Tamb≤+75°C Process temperature =85°C

Grade 1, Zone 2, Group D, ExtD A21 T100

-30°C≤Tamb≤+75°C Process temperature =100°C

Grade 1, Zone 2, Group D, Ex tD A21 T110

-30°C≤Tamb≤+75°C Process temperature =110°C

(Note-Use a power cord suitable for working at a temperature 5°C higher than the ambient temperature)

### ATEX Intrinsic Safety Certification

Grade 1, Zone 1, Group G, Ex ia IIC T4

-30°C≤Tamb≤+60°C Process temperature =105°C

### Electrical parameters:

Ui=30V, Li=93mA, Pi=1W, Ci=5nF, Li=0.5mH

Grade 1, Zone 1, Group D, and Ex ia D 20 T105

-30°C≤Tamb≤+60°C Process temperature=105°C

### NEPSI explosion certification

Ex d IIC T6 DIP A21 TA85°C

-30°C≤Tamb≤+75°C Process temperature=80°C

Ex d IIC T5 DIP A21 TA 100°C

-30°C≤Tamb≤+80°C Process temperature=95°C

Ex d IC T4 DIP A21 TA115°C

-30°C≤Tamb≤+80°C Process temperature=110°C

### NEPSI Intrinsic Safety Certification

Ex ia IIC T4

-30°C≤Tamb≤+60°C Process temperature=105°C

### Electrical parameters:

Ui=30V, Ii=100mA, Pi=1W, Ci=13nF, Li=0.5mH

### IECEX explosion certification

Ga/Gb Ex d IC T6

-30°C≤Tamb≤+75°C Process temperature=85°C

Ga/Gb Ex d IIC T5

-30°C≤Tamb≤+80°C Process temperature=100°C

Ga/Gb Ex d IC T4

-30°C≤Tamb≤+80°C Process temperature=110°C

Ex tD A21 T85

-30°C≤Tamb≤+75°C Process temperature=85°C

Ex tD A21 T100

-30°C≤Tamb≤+75°C Process temperature=100°C

Ex tD A21 T110

-30°C≤Tamb≤+75°C Process temperature=110°C

Note-Use a power cord suitable for working at a temperature 5°C above the surroundings

### IECEX safety safety safety certification

Zone 0, Ex ia IIC T4

-30°C≤Tamb≤+60°C Process temperature = 105°C

### Electrical parameters:

Ui=30V, Li=93mA, Pi=1W, Ci=5nF, Li=0.5mH Ex iaD 20 T105

-30°C≤Tamb≤+60°C Process temperature= 105°C

### Electromagnetic compatibility (EMC)

EN 61326-1:2013

EN 61326-2-3:2013

EN 61326-2-5: 2013

Electromagnetic compatibility directive: 2014/30/EU

### RoHS attestation

EN 50581:2012

EN 62321:2013

### Debug method

HART hand operator, local button

The HART manipulator can configure almost all instrument parameters.

The local button can make various functional configuration of the transmitter: zero adjustment, plus

Set the upper and lower measurement limits of pressure and no pressure measurement, unit selection, damping setting, export selection, etc.

### Display interface

Identification	Explain
PV	The main screen displays process variables, the secondary screen displays percentage and progress bar.
mA	The main screen shows the current value, and the secondary screen shows the percentage and progress bar.
%	Home screen display percentage, secondary screen display percentage and progress bar.

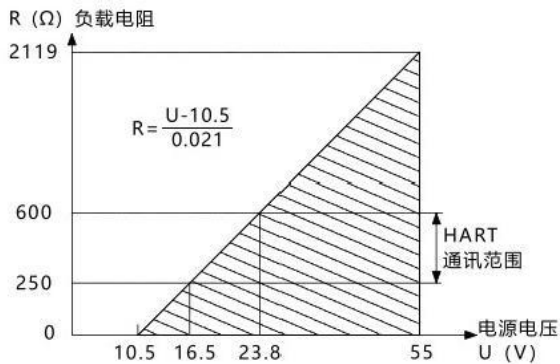

Figure 1. Power supply and load conditions

By standards, and test base conditions, including linear, sluggish, and repetitive. Calibration temperature: 20°C ± 5°C	
Linear transmission and output accuracy	± 0.025%, if TD > 10 (Note 10), ± (0.0025 TD)%
	± 0.05%, if TD > 10 (Note 1), then ± (0.005 TD)%
	Soil 0.075%, ± (0.0075 TD) if TD > 10% ± 0.1%, ± (0.01 TD) if TD > 10%
The square root export accuracy is 1.5 times the linear reference accuracy	
Note 1: TD = max. range / regulatory range	

Table 2 refers to the accuracy

### Overall dimension drawing (in mm)

#### JUN-E30-H Overall size drawing with display function

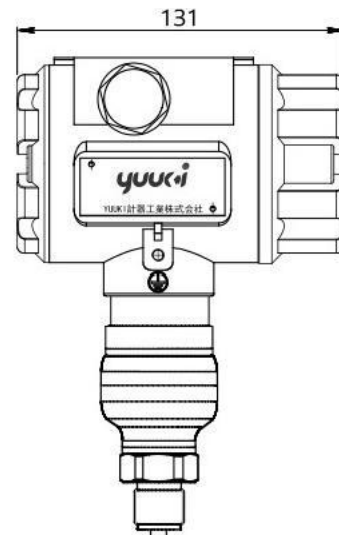
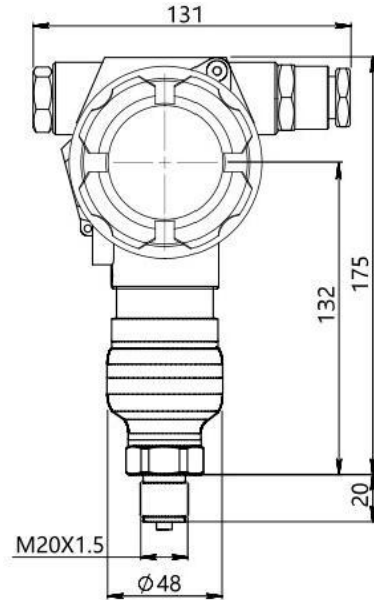

JUN-E30-S Overall size drawing with display function

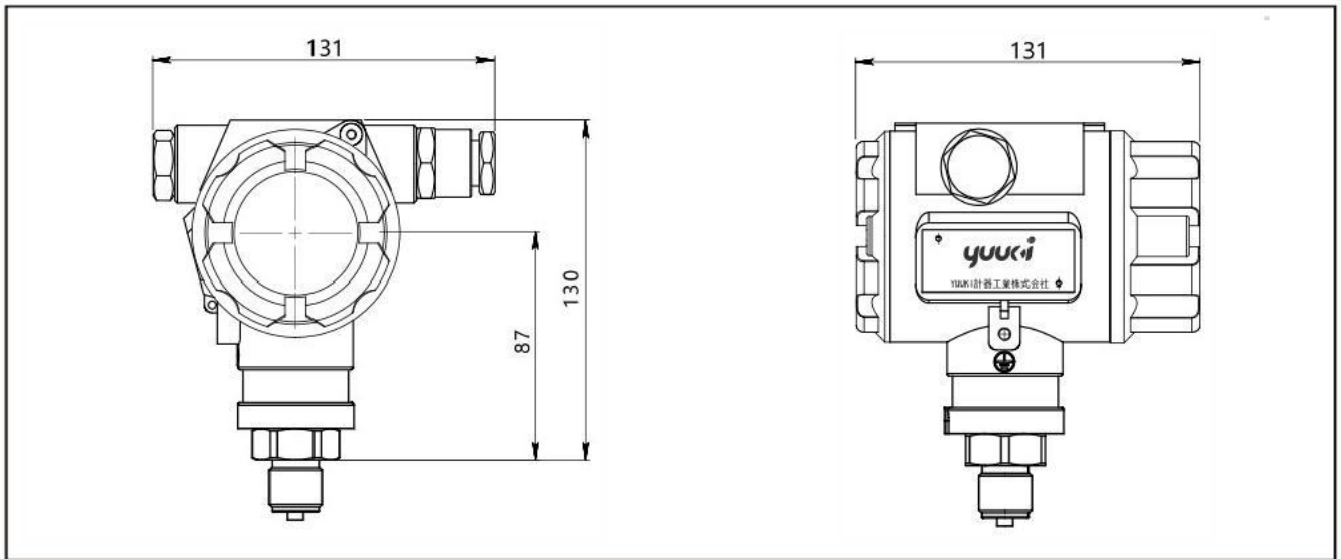

JUN-E30-H Size drawing of the whole machine without display function

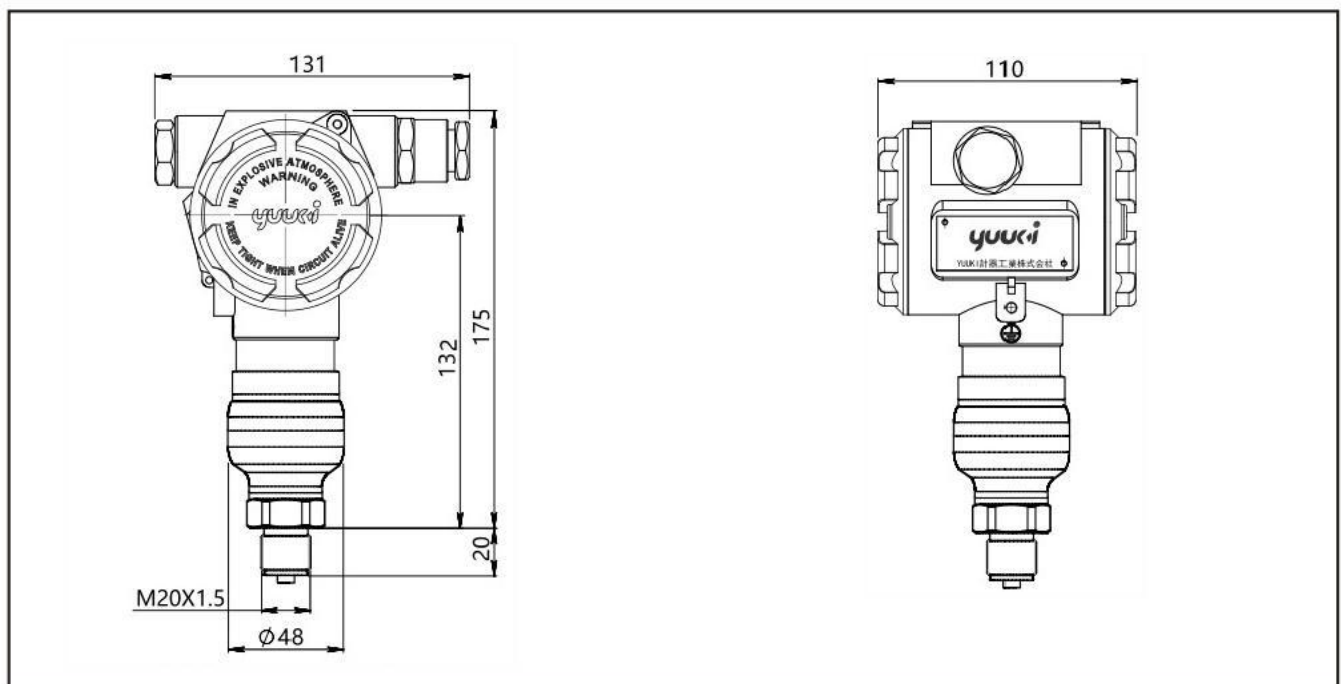

JUN-E30-S Size drawing of the whole machine without display function

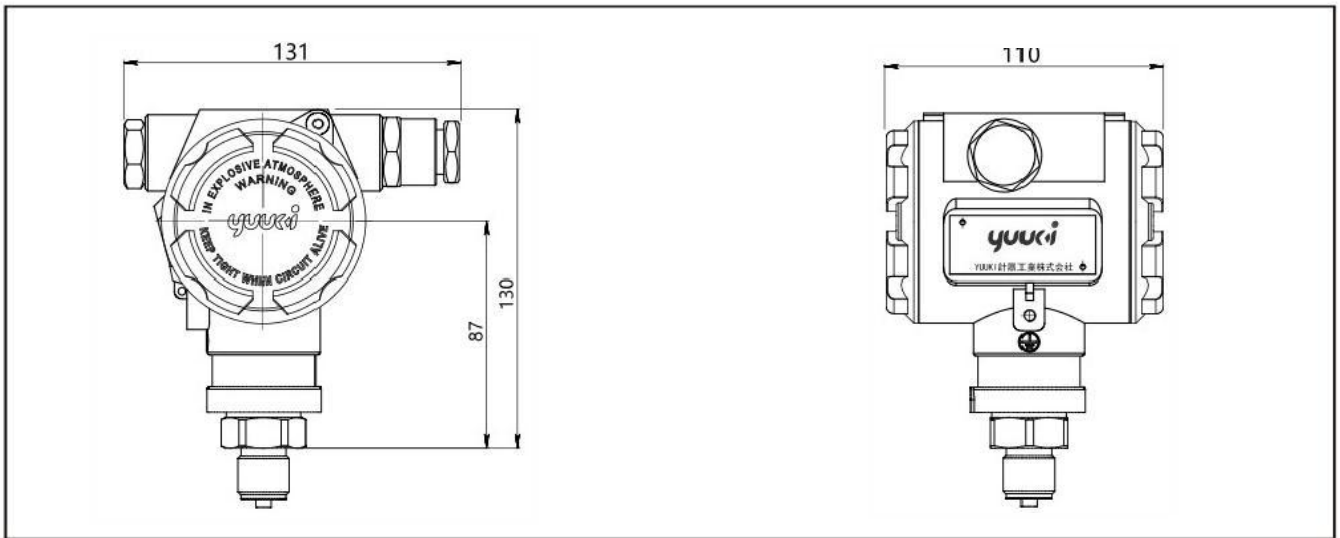

JUN-E30-H Installation dimensions of the fixed mounting bracket (B4)

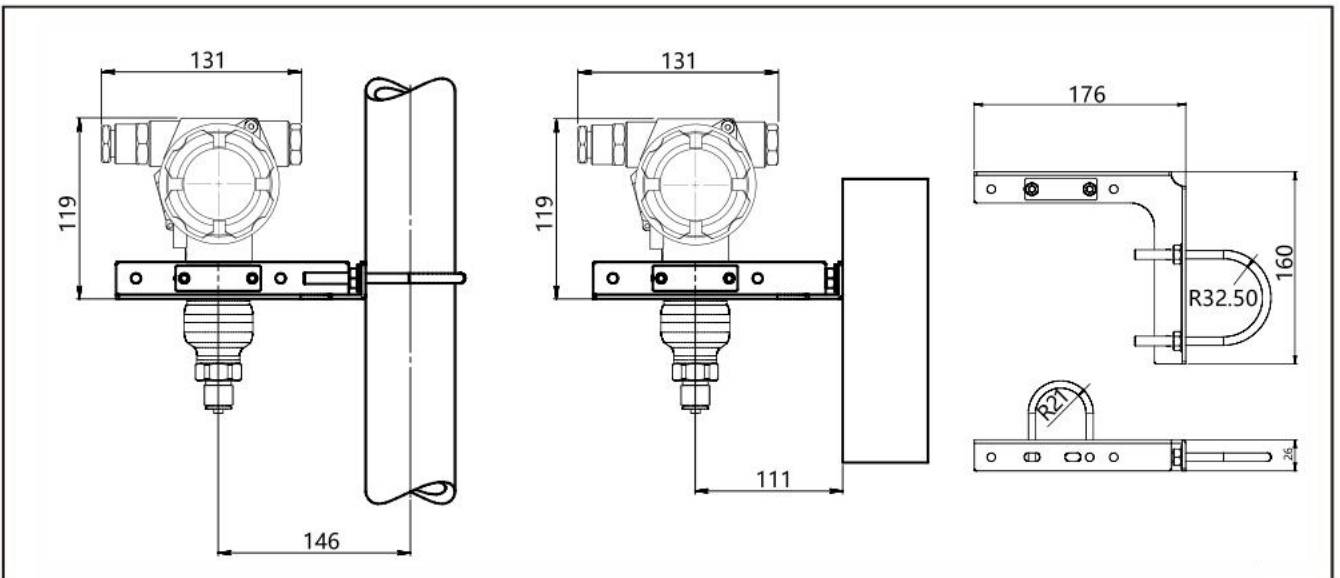

JUN-E30-S Installation dimensions of the fixed mounting bracket (B4)

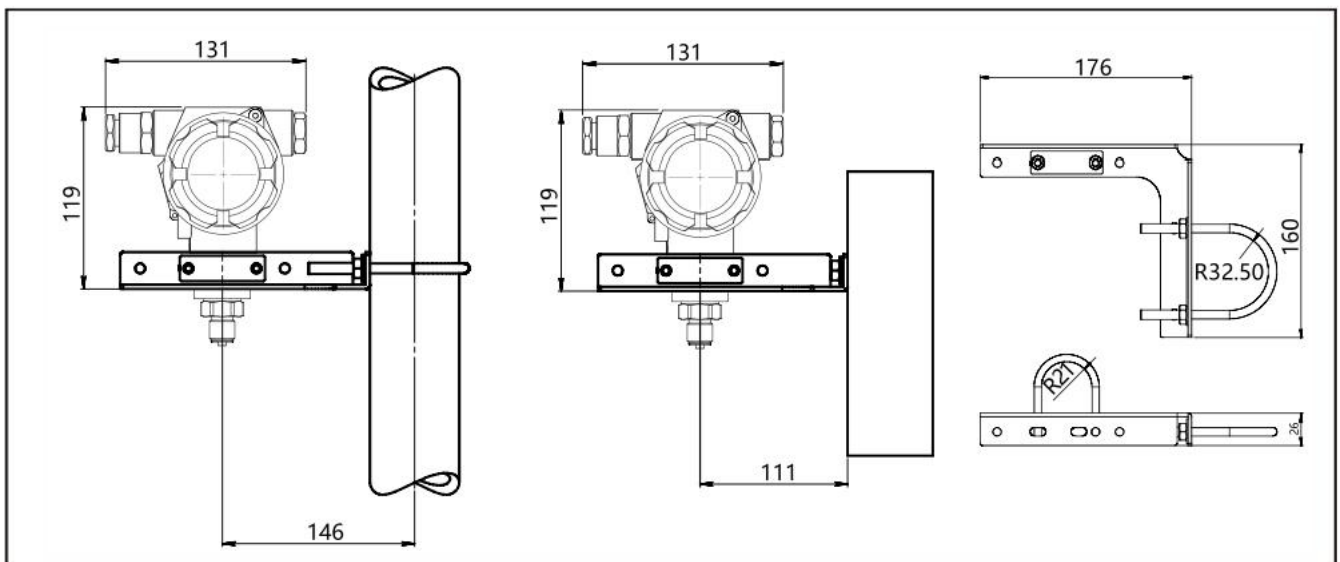

Pressure import into M01 dimension drawing

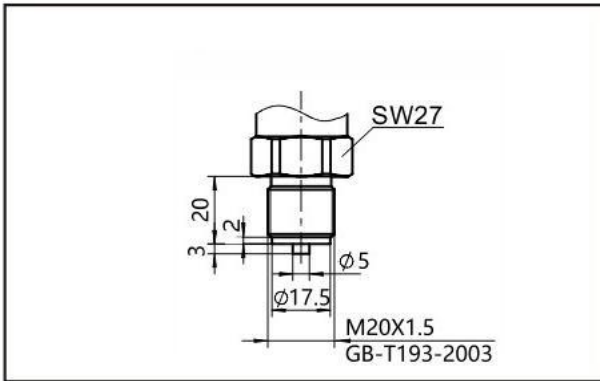

Pressure import into G01 dimension drawing

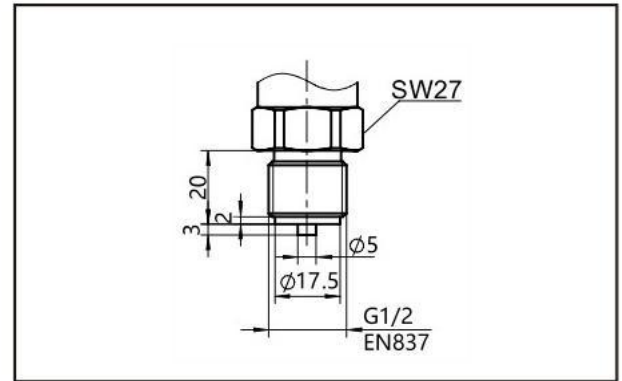

Pressure import G02 size drawing

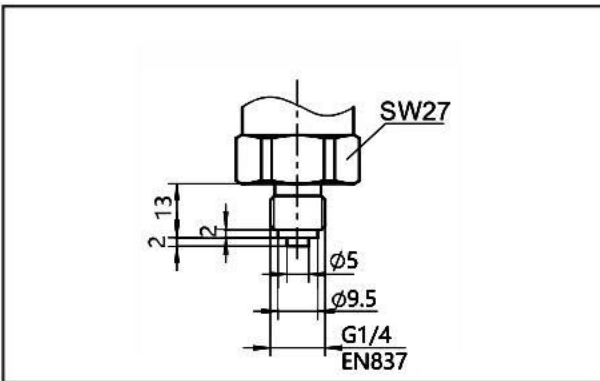

Pressure import G08 size drawing

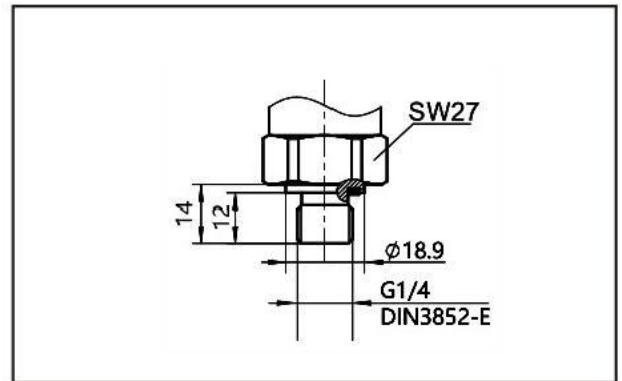

Pressure import into the R01 dimensional drawing

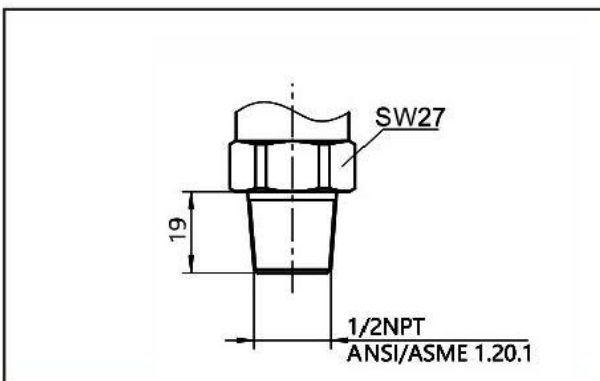

Pressure import into the R02 dimensional drawing

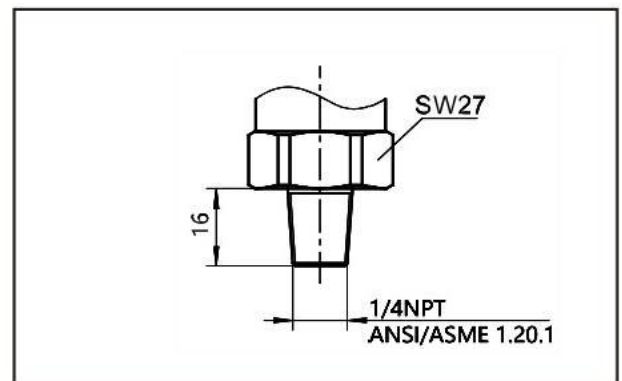

Pressure import into the R03 dimensional drawing

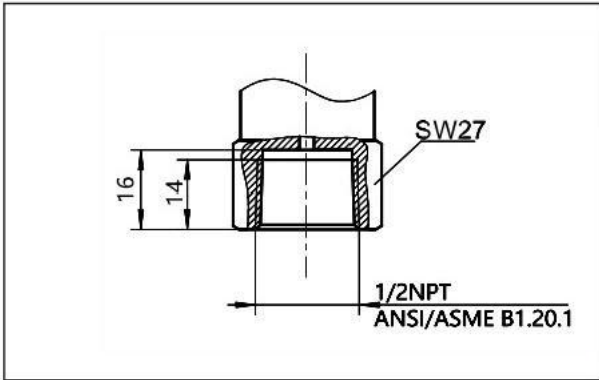

Pressure import into the drawing

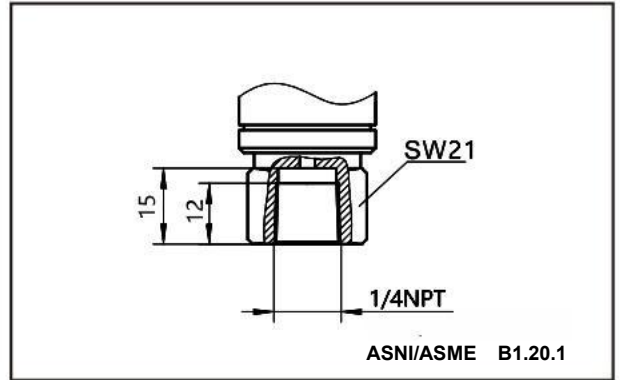

Size diagram of heat switching connector N1

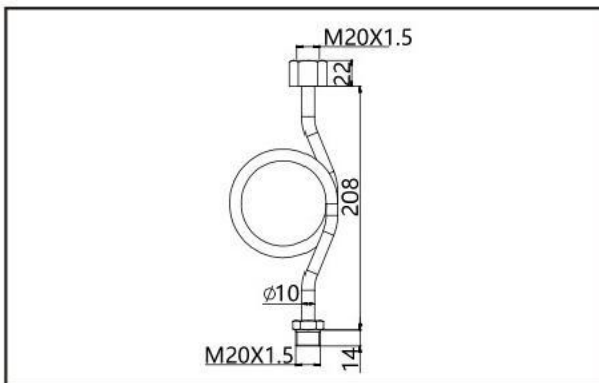

Size diagram of heat exchange connector N2

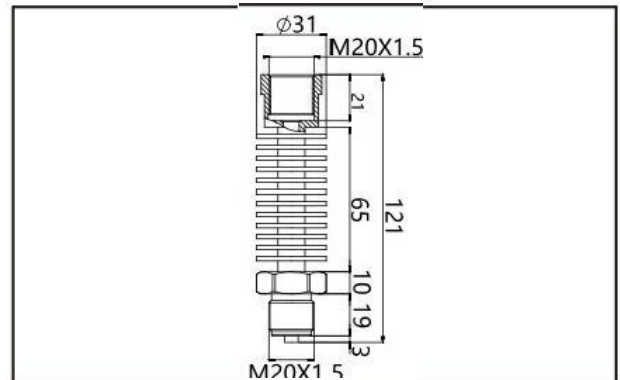

Pressure import Z1 dimension diagram

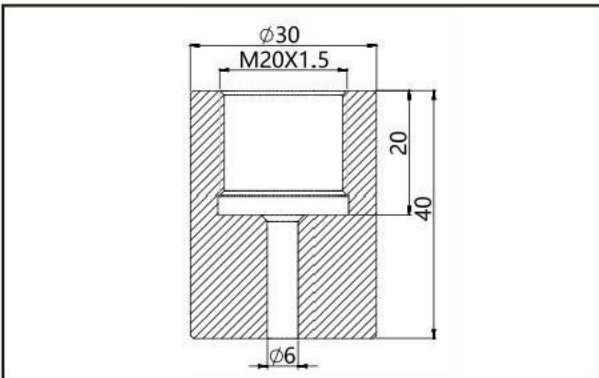

Pressure introduction into Z2 size drawing

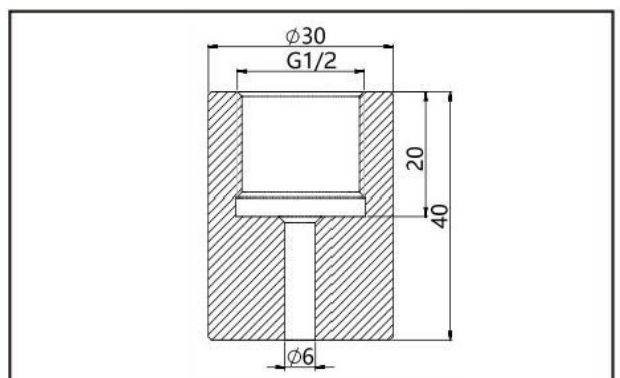

Order number	Project	Code	Content
1	Model	JUN-E30	Pressure relief transmitter
2	Accuracy	A	±0.05%
		B	±0.075%
		C	±0.1%
		D	±0.025%
3	Structure	S	normal structure
		H	Overload protection structure
4	Range	A40	0~40kPa, Minimum range 10kPa (voltage, 0Pa = absolute vacuum)
		A250	0~250kPa, Minimum range 12.5kPa (voltage, 0Pa = absolute vacuum)
		A1K	0~1MPa, Minimum range 50kPa (voltage, 0Pa = absolute vacuum)
		A10K	0~10MPa, Minimum range 500kPa (voltage, 0Pa = absolute vacuum)
5	Communication mode	H	4~20mA + HART, made in two lines
		P	PROFIBUS-PA (ask separately for delivery date)
		F	FOUNDATION Field-bus (Request separately)
6	Explosion-proof	N	No explosion-proof function
		G	PCEC explosion suppression
		D	NEPSI explosion suppression
		A	NEPSI Ben Ann
		E	ATEX explosion suppression
		B	ATEX Ben Ann
		M	IECEX explosion suppression
		W	IECEX Ben Ann
7	Show	N	No display
		L	LCD liquid-crystal display
		O	OLED display (ask later)
8	liquid diaphragm material	S	And 316L stainless steel
		U	The 316L stainless steel is gold-plated
		H	Hastelloy C
		T	Ta
		M	Monnell
9	Seal into the liquid	S	Silicone oil, applicable to the direct contact temperature range of -40 to 120°C
		D	Inert filling fluid for direct contact temperature range -45 to 160°C
10	Treatment of the solution site	0	No special treatment
		1	No oil treatment
		2	Water ban treatment

Order number	Project	Code	Content
11	Pressure import connection	R01	Outer thread 1 / 2 NPT-14, $\phi$ 3 lead pressure orifice, GB / T12716, ANSI / ASME B 1.20.1
		R02	Outer thread 1 / 4 NPT-18, $\phi$ 3 lead hole, GB / T12716, ANSI / ASME B 1.20.1
		R03	Inner thread 1 / 2 NPT-14, $\phi$ 3 lead pressure orifice, GB / T12716, ANSI / ASME B 1.20.1
		R04	Inner thread 1 / 4 NPT-18, $\phi$ 3 lead pressure orifice, GB / T12716, ANSI / ASME B 1.20.1
		M01	Outer thread M20 * 1.5, $\phi$ 3 lead hole, GB / T193-2003, ISO 261
		M02	Inner thread M20 * 1.5, $\phi$ 3 lead hole, GB / T193-2003, ISO 261
		G01	External thread G1 / 2, $\phi$ 3 lead hole, EN 837
		G02	External thread G1 / 4, $\phi$ 3 lead hole, EN 837
		G08	Outer thread G1 / 4A, $\phi$ 3 lead hole, GB / T7307, ISO 228, DIN 16288, BS 2779, seal reference DIN 3852-E (rear seal)
12	Distribution connection	T1	Two M20 * 1.5 internal thread electrical interfaces
		R1	Two M20 * 1.5 internal thread electrical interface, one side with M 20 * 1.5 waterproof joint, the other side with PVC material plug
		R2	With inner thread 1 / 2 NPT connector on one side and stainless steel plug on the other side
		R3	One side inner thread M20 * 1.5 joint, the other side with stainless steel plug
13	Additional options-Fixed mounting fittings	-B4	U-shaped bracket, 2 " tube mounting
14	Additional Options-Pressure guide mounting accessories	-N1	Heat exchange connector, 304 stainless steel bend, M20 * 1.5 inner thread to M20 * 1.5 outer thread
		-N2	Heat exchange connector, 304 stainless steel bellows, M20 * 1.5 inner thread to M20 * 1.5 outer thread
15	Additional option-the pressure import attachment	-Z1	Welded connector, M20 * 1.5, 304 stainless steel
		-Z2	Welded connections, G1 / 2, 304 stainless steel
16	Additional option-welded pipe joint	-C	1 / 2 NPT to $\phi$ 14 welded pipe joint
17	Additional option-Valve set	-1	Two valve group, 304 stainless steel material
		-2	Two valve group, 316 stainless steel material
18	Additional option-Check the report	-Q2	Provide a nationally recognized third-party verification report

### Matters need attention

To better perform the performance of the transmitter, please pay attention to the following before use and read the instructions.

#### Note for transmitter installation

Notice
<p>When installing the transmitter, ensure that the sealing gasket is connected in the process, not from the transmitter to the process fluid such as fitting flange connection, connecting pipe</p> <p>Lane, flange) connected prominent, if the sealing gasket protruding outside, may lead to liquid leakage and output errors. Do not use the transmitter beyond the specified pressure, temperature range and operating conditions of the product specification, otherwise it may cause the leakage of the product and cause serious accidents.</p> <p>When wiring in dangerous areas, please follow the operation method specified in the explosion-proof standard instructions.</p>

#### Use the HART protocol equipment notice matters

If the instrument is operated by the helper (HART Communicator, etc.), set the communication interval of the server (DCS, equipment management system) for more than 8 seconds, or stop the communication between the server and the instrument. If the server communicates with the instrument repeatedly within 8 seconds, the instrument may not accept the request of the helper (may not be able to communicate with the instrument).

If the electrical noise interference in the surrounding environment affects the HART communication with the server, please take corresponding measures, such as separating the signal cable from the noise source, improving the grounding or replacing the signal shielding cable, etc. If an analog signal of 4-20mA is used, the use will not be affected even if the HART communication is disturbed by the noise

Notice
<p>Please do not stand on the installed transmitter, take it as a foot.foot may occur splash, causing fluid splash injury personnel.</p> <p>Be careful of the glass display, do not use tools to hit the glass part of the digital watch head, breaking the glass may cause body injury.</p> <p>The transmitter is heavy, please carefully install and wear safety shoes.</p> <p>The collision transmitter may damage the sensor module.</p>

#### Wiring notice matters

Warning
<p>To prevent a short circuit, please do not use wet hands or in a live state of the wiring work.</p>

Notice
<p>Please connect correctly according to the technical specification. Wrong wiring will cause instrument failure or irreparable damage.</p> <p>Please use the power supply that meets the technical specification. Using the inappropriate power supply can cause instrument failure or irreparable damage.</p>

△ Before using the product, please read the operation manual carefully.

△ Changes in some appearance or specifications due to improvement without notice.